

Lindon Bench Banc Lindon

Assembly Instructions / Instructions d'assemblage

URBAN BARN

Parts Packing Configurations / Pièces et configuration

- A. Seat / Siège x 1
- B. Stretcher / Barre transversale x 1
- C. Leg C / Patte C x 2
- D. Leg D / Patte D x 2
- E. Side Stretcher / Barre latérale x 2

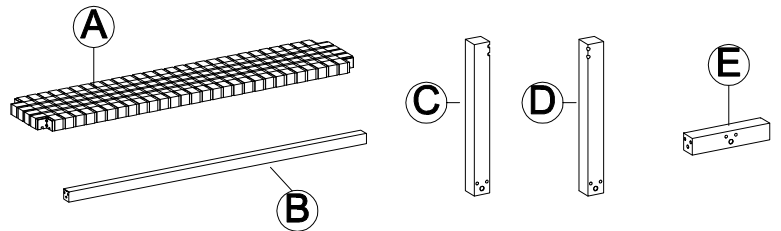

Hardware Kit Packed in Box Quincaillerie incluse dans la boîte

No	Description	Image	Qty / Qté
1	Allen Bolt (5/16" x 3") Boulon Allen (5/16 po x 3 po)		x 8
2	Lock Washer (5/16") Rondelle d'arrêt (5/16 po)		x 8
3	Flat Washer (5/16") Rondelle plate (5/16 po)		x 8
4	Allen Key (5mm) Clé Allen (5 mm)		x 1
5	Threaded Bolt (5/16" x 3") Boulon fileté (5/16 po x 3 po)		x 6
6	Half Moon Washer (28 x 14 x 7mm) Écrou demi-lune (28 mm x 14 mm x 7 mm)		x 6
7	Hex Nut (5/16") Écrou à tête hexagonale (5/16 po)		x 6
8	Wrench Cle		x 1
9	Wood Dowel (8 x 30mm) Tige en bois (8 mm x 30 mm)		x 12

Bench Fully Assembled Banc assemblé

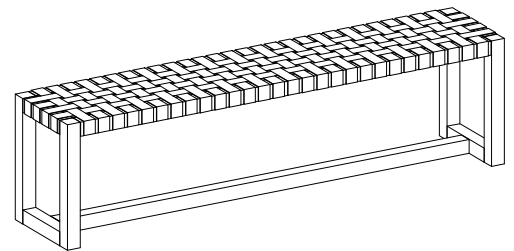

Step 1 Étape 1

#5 (4) #9 (8)

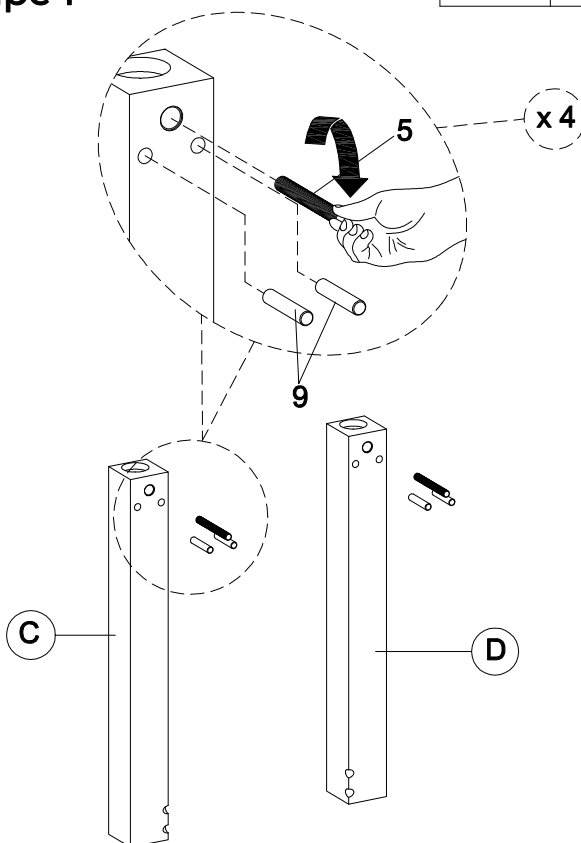

Step 2 Étape 2

#6 (4) #7 (4)

Note: Do not fully tighten hex nuts until final step.

Note : Attendre à la dernière étape pour bien serrer tous les écrous à tête hexagonale.

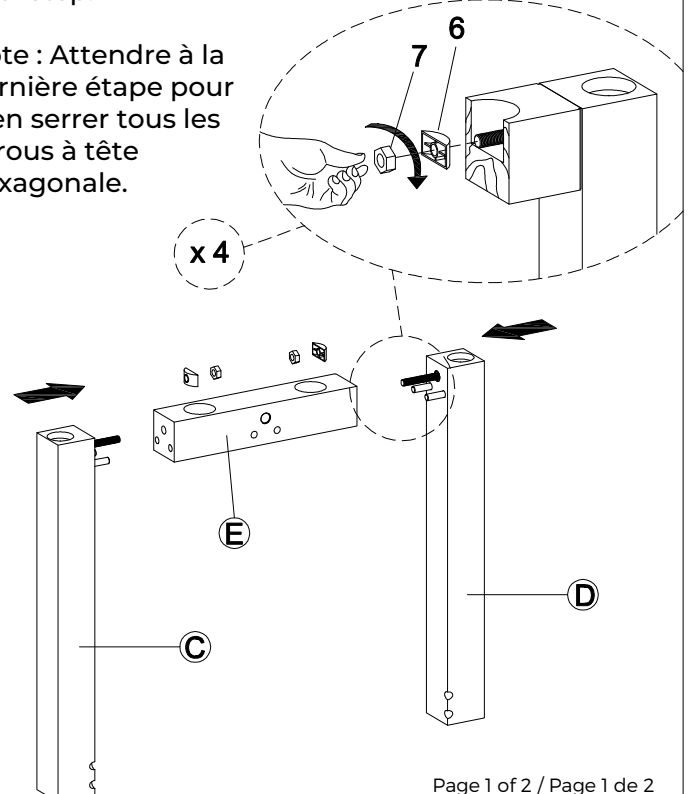

Lindon Bench Banc Lindon

Assembly Instructions / Instructions d'assemblage

URBAN BARN

Step 3 Étape 3

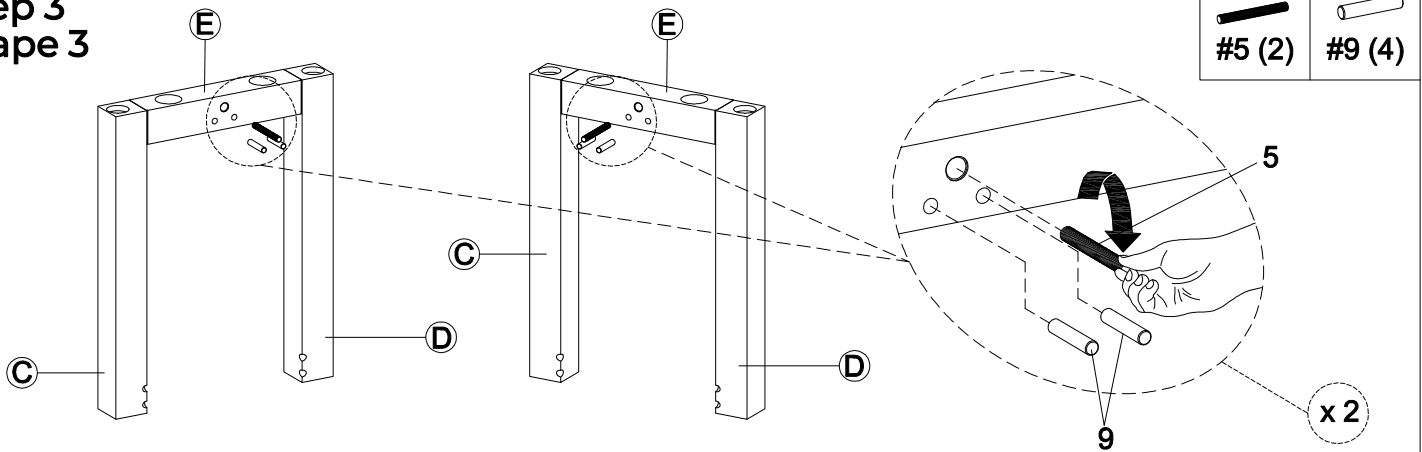

Step 4 Étape 4

Note: Do not fully tighten hex nuts until final step.

Note : Attendez à la dernière étape pour bien serrer tous les écrous à tête hexagonale

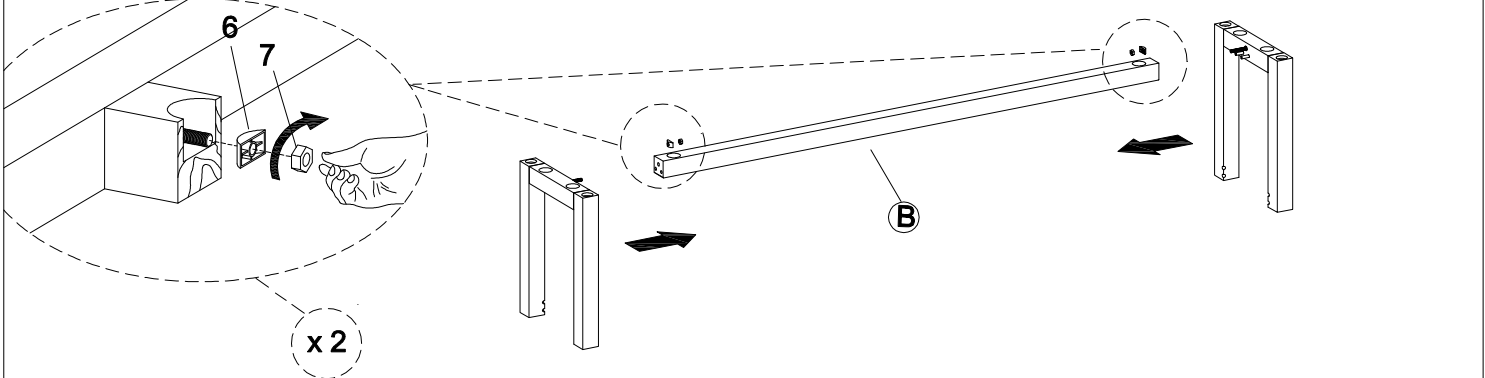

Step 5 Étape 5

Note: Fully tighten all hex nuts and bolts from this and previous steps.

Note : Bien serrer les écrous, y compris ceux des étapes précédentes.

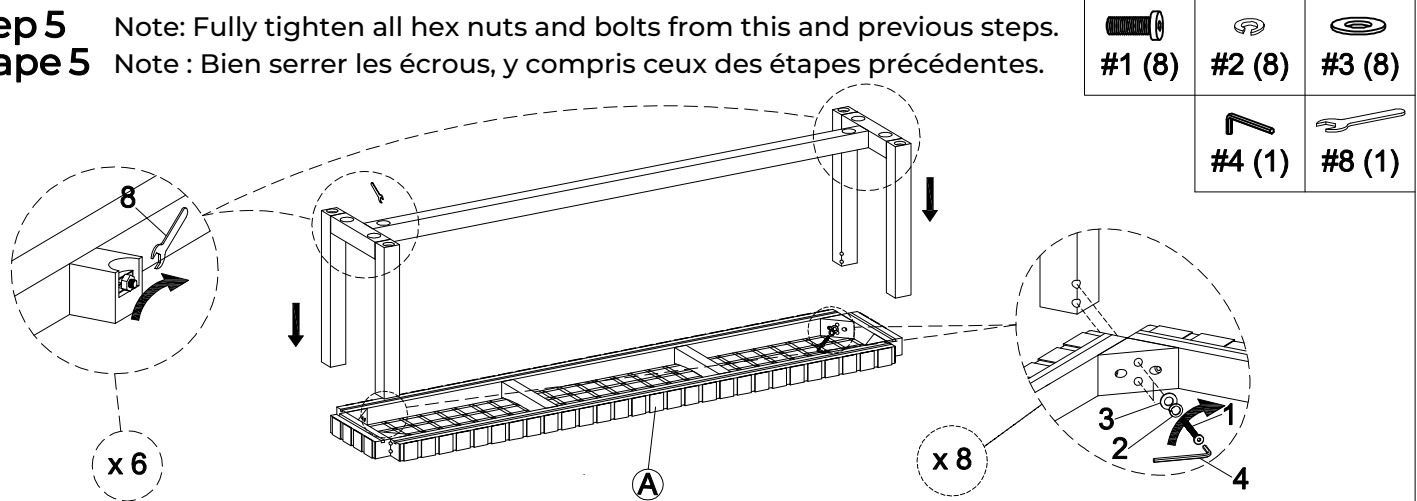

Assembly Complete Assemblage complété

